



## Exergoeconomic and Ecological Efficiency Analysis of Steam Generation System in Ecuadorian Tuna Industry



Ángel Rafael Arteaga-Linza<sup>a</sup>

Ángel Luis Brito-Sauvanell<sup>b</sup>

María Isabel Fernández-Parra<sup>c</sup>

### Article history:

Received: 10 November 2017

Revised: 25 February 2018

Approved: 20 March 2018

Published: 27 March 2018

### Keywords:

Canned tuna;

Steam boilers;

Thermoeconomic;

Exergy efficiency;

Ecological efficiency;

### Abstract

The present work was developed, in the steam generation system of a canned tuna canning plant in Ecuador, in which an exergoeconomic and ecological efficiency analysis was applied in combination, with a view to identifying and quantifying the irreversibility's existing in the process under study, and evaluate the environmental impact produced by the fuel used by this type of facility. The methodology used combined from the literature consulted, the analysis of conventional exergy and exergoeconomic with the ecological efficiency. The results obtained were: the greater destruction of exergy was caused by the steam boiler (with more than 98% of the whole system) for an exergy efficiency of 25.12%; the unit thermoeconomic cost of steam generated by the system is \$ 28.07 / GJ; and the ecological efficiency of the steam generator of the industrial plant is 46.27%, with the use of fuel oil 6 as fuel and a thermal efficiency of 84.91%. These results show the need to increase the parameters of steam generation (pressure and temperature), as well as to evaluate the possibility of using other fuel alternatives, to improve the energetic and ecological effects of the tuna plant under study.

2454-2261 ©Copyright 2018. The Author.

This is an open-access article under the CC BY-SA license

(<https://creativecommons.org/licenses/by-sa/4.0/>)

All rights reserved.

### Author correspondence:

Ángel Rafael Arteaga-Linza,

Doctorate Program, mechanical Engineering,

Universidad Técnica de Manabí, Facultad de Ciencias, Matemáticas, Físicas y Químicas,

Portoviejo, Manabí Ecuador, Email address: [aarteaga@utm.edu.ec](mailto:aarteaga@utm.edu.ec)

### 1. Introduction

Today, most of the energy used by the food industry is provided through non-renewable resources such as fossil fuels; However, the rapid depletion of these and their fluctuations in prices worldwide, have required the search for tools that contribute to the efficient use of energy in industries [1]. On the other hand, the extensive use of fossil fuels generates greenhouse gas emissions (CO, CO<sub>2</sub>, SO<sub>x</sub>, and NO<sub>x</sub>) and subsequent environmental concerns [2].

<sup>a</sup> MsC. Universidad Técnica de Manabí, Facultad de Ciencias, Matemáticas, Físicas y Químicas, Portoviejo, Manabí Ecuador

<sup>b</sup> Ph.D. Universidad de Oriente, Facultad de Mecánica, Santiago de Cuba, Cuba

<sup>c</sup> Ph.D. Universidad de Oriente, Facultad de Mecánica, Santiago de Cuba, Cuba

In the canned tuna canning process, steam is the most suitable means of transporting the heat demanded by the different processes, such as cooking, packing, sterilizing and labeling, to convert the tuna into a finished product [3], so the steam generation plant is considered a key system, whose function is vital in the production process [4], [5].

Given the contaminating nature of fossil sources, it is necessary to reduce the consumption of these energy carriers, based on the optimization and periodic evaluation of existing technologies and the design of others [6], for which the exergoeconomic analysis is a useful tool for industrial energy systems, when improvements are sought related to energy consumption and emissions, allowing to identify and quantify inefficiencies and irreversibilities that occur in energy conversion processes [7], [8]. This would result in fuel savings and lower environmental impact [4].

The use of fossil fuels in the steam production process has a high environmental cost if one takes into account that they come from non-renewable sources. This situation, together with the large number of installed equipment with high degrees of oversizing and low efficiency, cause that the generation of steam contributes negatively to the environmental impact due to CO<sub>2</sub> emissions [9], which is why it is done necessary, to carry out studies on the impact of greenhouse gas emissions generated by industrial activity. In this context, ecological efficiency emerges as a parameter that contributes to perfecting current production technologies [10], [11].

Within the bibliographies reviewed, different investigations have been carried out, which demonstrate the importance of exergoeconomic and ecological efficiency analysis in the different sectors of the industry [12], [7] [11], [13], [14], [15], [8], [16]; however, in the tuna industry only works have been found on the tuna life cycle [17] [3] and the exergy analysis of its production process [18], but none that perform exergo-economic analysis and ecological efficiency of the system complete or the steam generation subsystem, which is essential to contribute to the reduction of the use of energy carriers, as well as the emissions of polluting gases, aspects that represent today a problem that concerns humanity. For this reason, the objective of this work is to apply a combination of an exergoeconomic and ecological efficiency analysis, to the steam generation system of a canned tuna canning plant in Ecuador, with a view to contributing to the continuous improvement of its exergetic and ecological efficiency.

This work is part of a project financed by the Ecuadorian government, through its scholarship program of the National Secretariat of Science, Technology, and Innovation (SENESCYT), and was carried out in one of the transnational companies processing canned tuna in cans in the Republic of Ecuador

## 2. Research Methods

For the realization of the present work the values of the thermal parameters of the steam and the water were taken, in the different points of the steam generation and distribution system, according to the methodology proposed [22]. Regarding the energy and exergy analyzes were carried out applying a methodology that consists of two main stages, described in this article

### Description of the plant

In this paper, the steam generation and supply system of an existing industrial plant for canned tuna canning are analyzed, where the main function of the energy system is the production of saturated steam at the pressure of 8.728bar. The entire system is divided into 19 main components interconnected with 34 fluid streams. The system consists of 2 main subsystems, the water supply, and the fuel subsystem. The scheme of the system, its components, and the currents are illustrated in Figure 1, which shows the flow diagram of the steam generation and supply system of the industrial plant under study.

To carry out the study, the values of the steam and water parameters were taken at the different points of the steam generation and supply system, especially the entry and exit of each element, from which they were carried out. the analyzes applying a methodology that consists of two main stages.

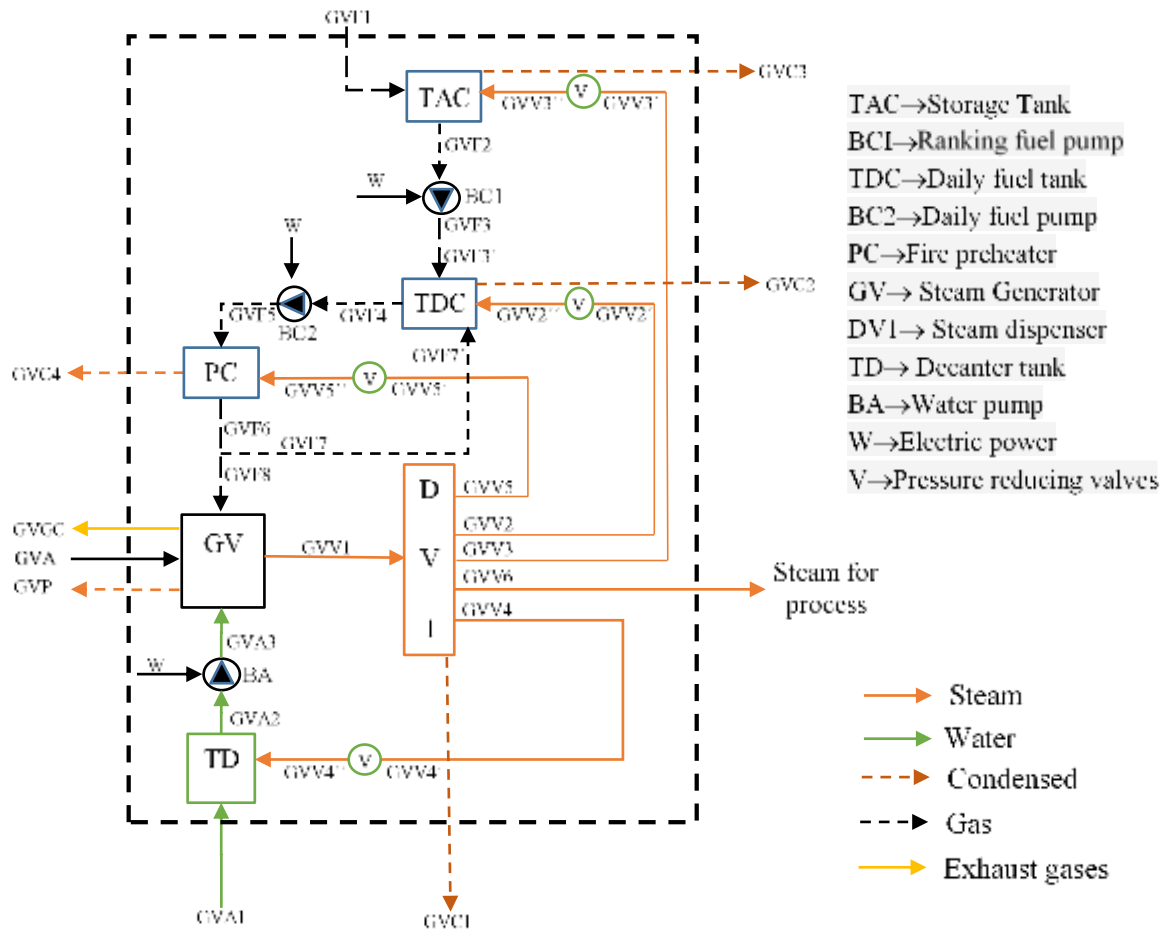

Figure 1. Flow diagram of the generation system

**Stage 1. Analysis of conventional exergy and exergoeconomic**

The analysis of conventional exergy and exergoeconomic was carried out using the first and second law of thermodynamics, following the methodology proposed [19] and used in different studies conducted in the industrial sector [4], [20], [8], [16]. For the measurement of the thermodynamic parameters of the system, it was considered that the operation of its components was in a stationary state. The applied methodology starts from a mass balance, followed by an energy balance developed according to the first law of thermodynamics, the final exergy and thermoeconomic balances were developed by the method exposed by [21] in the literature, shown in the equations (1 and 2).

$$\dot{E}_{F_{\gamma,k}} = \dot{E}_{P_{\gamma,k}} + \dot{E}_{L_{\gamma,k}} + \dot{E}_{D_{\gamma,k}} \tag{1}$$

$$\dot{C}_{P_{\gamma,k}} = \dot{C}_{F_{\gamma,k}} + \dot{Z}_k^{Cl} + \dot{Z}_k^{OM} \tag{2}$$

One of the essential assumptions is that the cost rate of each flow (j) is calculated according to the exergy value as observed in equation (3).

$$\dot{C}_j = \dot{c}_j \dot{E}_j \tag{3}$$

One of the most important criteria for the evaluation of the system or components from the thermodynamic point of view is the exergetic efficiency, defined as the ratio of the exergy values of product to fuel, as shown in equation (4).

$$\varepsilon_k = \frac{\dot{E}_{P,k}}{\dot{E}_{F,k}} = \frac{\dot{E}_{P,k}}{\dot{E}_{P,k} + \dot{E}_{L,k} + \dot{E}_{D,k}} = \left(1 + \frac{\dot{E}_{L,k} + \dot{E}_{D,k}}{\dot{E}_{P,k}}\right)^{-1} \quad (4)$$

A useful variable for the comparison of dissimilar components is the destruction rate of exergy defined in equation (5).

$$y_{D,k} = \frac{\dot{E}_{D,k}}{\dot{E}_{F,tot}} \quad (5)$$

This ratio is a measure of the contribution of the destruction of the exergy of component k to the reduction of total exergy efficiency.

### Stage 2. Ecological efficiency analysis

The ecological efficiency analysis was carried out using the methodology proposed by Cardu M. & Baica M. [10] and applied to different industrial processes by several authors [12], [11], taking into account the modification proposed by Coronado [14] for the calculation of ecological efficiency.

The methodology applied for the determination of ecological efficiency evaluates the amount of pollutant in the steam generation and supply system of the industrial plant under study, considering the polluting emissions per Kg of fuel used. This efficiency is between 0 and 1; where an ecological efficiency equal to 0 means 100% of environmental impact or high pollutant, and an efficiency equal to 1 means 0% of the environmental or non-polluting impact. Cardu, M. & Baica, M. [10] introduced the concept of equivalent carbon dioxide ( $CO_2$ ) e, based on the maximum allowed concentration for  $CO_2$ , which is 10,000 mg / m<sup>3</sup>. The equivalent coefficients for some pollutants in kg per kilogram of fuel (kg/kg of fuel), called global warming potential (GWP), are related according to equation (6).

$$(CO_2)e = CO_2 + 1,9(CO) + 1000(NO_x) + 666(SO_2) + 222(PM) \quad (6)$$

The cited authors themselves propose an indicator to quantify the environmental impact, which is defined as the ratio between the carbon dioxide equivalent of the fuel and its lower heating value. This indicator is called the pollution indicator represented by  $\Pi_g$ , equation (7).

$$\Pi_g = \frac{(CO_2)e}{LHV} \quad (7)$$

Where:

( $CO_2$ ) e → equivalent of carbon dioxide (kg / kg of fuel);

LHV → inferior calorific value of the fuel (MJ / kg of fuel);

$\Pi_g$  → indicator of contamination (kg / MJ).

Based on the assumption that the best fuel is the one with the lowest pollution indicator, they propose a more complex and dimensionless index that expresses the ecological component of the polluting gases emitted into the atmosphere by the combustion of a certain fuel in the atmosphere. comparison with the useful energy produced in thermal power plants. The proposed indicator is called ecological efficiency ( $\varepsilon$ ), like equation (8).

$$\varepsilon = \left[ \frac{0.204 \times \eta_{system}}{\eta_{system} + \pi_g} \times \ln(135 - \Pi_g) \right] \quad (8)$$

For their part [14] they propose and argue a modification to the ecological efficiency formula originally presented by Cardu, M. & Baica, M. [10], for the cases in which the cooking is carried out in small boilers such as the tuna industry, taking into account that the values of the dimensionless coefficients depend on the process analyzed by Ferreira, J. and other authors [23]. For this reason, the following equation (9) is assumed for the calculation of ecological efficiency.

$$\varepsilon = \left[ 0.2 \cdot \frac{\eta}{\eta + \Pi_g} \cdot \ln(145.6 - \Pi_g) \right]^{1.9} \quad (9)$$

### 3. Results and Analysis

#### 3.1 Results of stage 1 of analysis of conventional exergy and exergoeconomic

The thermodynamic parameters of the 34 flow streams are presented in table 1, the input data for the calculation of the thermodynamic parameters of the selected currents were obtained from in situ measurements. The results of thermodynamic, exergnetic and exergo-economic analyzes for all currents are presented in table 1. The input data for the calculation of pressures and temperatures were obtained from in situ measurements. Fuel costs (Fuel Oil # 6), electric power and water were taken from the official rates in force in the Republic of Ecuador, it was also considered that the cost of air provided is zero. Operating and maintenance costs were calculated using the annual operating and maintenance real costs assuming 5808 hours of operation per year. Chemical exergy values are included for all fuel flows because they are significant, but not in the water and steam flows that are insignificant values that were omitted.

To solve the defined system of mathematical equations, software for solving equations was used. The results of the exergy analysis and the exergoeconomic evaluation at the component level for the real operating conditions are presented in table 1.

Table 1  
Thermodynamic, exergytical and exergo-economic analysis of each steam generation system stream

Flow	mj (kg/s)	pj (bar)	tj (°C)	hf (kj/kg)	sj (kj/kgK)	Ej (kW)	cj (\$/h)	cCj (\$/GJ)
GVA1	1,08	1,01	40	167,61	0,572	1,651	3,14	528,3
GVA2	1,11	1,01	52,7	220,71	0,738	5,6	4,99	247,7
GVA3	1,11	10,45	53	222,77	0,742	6,761	5,87	241,2
GVV1	0,97	8,72	174	2771,8	6,632	776,8	0,02	26,91
GVV2	0,01	8,72	174	2771,8	6,632	3,775	0,38	28,07
GVV2'	0,01	8,67	174	2745,2	6,575	3,73	0,38	28,41
GVV2''	0,01	3,01	143	2745,2	7,039	3,076	0,38	34,44
GVV3	0,01	8,72	174	2771,8	6,632	9,526	0,96	28,07
GVV3'	0,01	7,82	170	2668	6,492	9,032	0,96	29,6
GVV3''	0,01	3,01	134	2668	6,899	7,578	0,96	35,28
GVV4	0,02	8,72	174	2771,8	6,632	18,317	1,85	28,07
GVV4'	0,02	8,64	174	2727,1	6,536	17,946	1,85	28,65
GVV4''	0,02	2,51	132	2727,1	7,578	14,25	1,85	36,06
GVV5	0,01	8,72	174	2771,8	6,632	4,337	0,42	28,07
GVV5'	0,01	8,71	174	2745,2	6,602	4,31	0,42	28,24
GVV5''	0,01	2,01	145	2745,2	7,251	3,259	0,42	37,35
GVV6	0,92	8,72	174	2771,8	6,632	736,96	0,02	28,07
GVP	0,13	8,72	174	736,8	2,081	16,06	0	0

GVC1	0,01	8,72	174	736,8	2,081	0,592	0	0
GVC2	0,01	3,01	134	562,1	1,673	0,32	0	0
GVC3	0,01	3,01	134	562,1	1,673	0,8075	0	0
GVC4	0,01	2,01	120	505,6	1,532	0,2891	0	0
GVF1	0,07	1,01	40	73,52	---	3220,9	59,29	5,113
GVF2	0,07	1,01	54,8	102,8	---	3221,1	60,26	5,198
GVF3	0,07	10,71	55	103,2	---	3221,1	60,91	5,254
GVF3'	0,07	1,01	42	77,41	---	3220,9	60,91	5,255
GVF4	0,16	1,03	52,8	98,74	---	7152,9	136,73	5,31
GVF5	0,16	6,9	53	99,15	---	7152,9	136,8	5,313
GVF6	0,16	5,49	80	155,1	---	7154,2	137,3	5,329
GVF7	0,09	5,49	80	155,1	---	3932,5	75,46	5,329
GVF7'	0,09	1,01	55	103,2	---	3931,8	75,46	5,33
GVF8	0,07	5,49	80	155,1	---	3221,7	61,81	5,329
GVA	1,94	1,01	30	417,99	---	3,361	0	0
GVGC	2,03	1,01	200	5836	---	159,5	0	0

The results of the conventional exergy analysis and the exergoeconomic evaluation of each component of the system for the real operating conditions are presented in table 2.

Table 2  
The result of the conventional exergetic and exergoeconomic analysis of each component of the system

Component (K)	Conventional exergy analysis			Exergoeconomic performance evaluation			
	$E_{F,k}$ (kW)	$E_{P,k}$ (kW)	$E_{D,k}$ (kW)	$\epsilon_K$ (%)	$Y_{DK}$ (%)	Zk (\$/h)	$C_{Dk}$ (\$/h)
TD	15,91	5,60	10,31	35,21	0,316	0,02	3,191
VR_TD	17,95	14,25	3,69	79,43	0,113	0	0,367
BA	2,28	1,16	1,12	53,17	0,034	0,14	0,101
GV	3066	770,10	2311,9	25,12	70,94	6,10	44,63
VR_TAC	9,03	7,58	1,46	83,90	0,045	0	0,15
TAC	6,77	0,21	5,55	3,14	0,17	0,03	0,76
BC1	0,03	0,003	0,026	58,89	0,0008	0,01	0,002
VR_TDC	3,73	3,08	0,65	82,48	0,019	0	0,065
TDC	2,76	0,109	2,65	3,96	0,081	0,02	0,23
BC2	0,07	0,007	0,06	67,94	0,0018	0,01	0,035
VR_PC	4,31	3,26	1,05	75,61	0,032	0	0,103
PC	2,97	1,338	1,63	45,05	0,05	0,01	0,23
DV1	776,80	772,90	3,9	99,50	0,12	0,01	0,248
GVV4-GVV4'	18,32	17,95	0,37	97,98	0,011	0	0,030
GVV3-GVV3'	9,53	9,03	0,5	94,82	0,015	0	0,044
GVF3-GVF3'	3221	3220,8	0,02	99,99	0,0006	0	0,001
GVF7-GVF7'	3932,57	3931,8	0,77	99,98	0,024	0	0,003
GVV2-GVV2'	3,78	3,73	0,05	98,67	0,0015	0	0,004
GVV5-GVV5'	4,34	4,31	0,03	99,39	0,0009	0	0,002
Energy supplied	3258,89	737	2345,74	22,62	71,976	6,35	

---

<b>EL TOTAL</b>	176,154
-----------------	---------

---

### 3.2 Results of stage 2 of ecological efficiency analysis

The use of the methodology of ecological efficiency in the present study, allowed to quantify the environmental impact of the steam generator of the system of the industrial plant for canned tuna canning object of study. The results of the polluting emissions of Fuel Oil # 6 used as fuel for steam generation by the system are presented below in Table 3.

Table 3  
Resultado de las emisiones contaminantes del Fuel Oil # 6

Emission of fuel contaminants (kg/kg)		Fuel Oil
CO	(CO <sub>2</sub> ) e	16,94
	PM	1,98x10 <sup>-4</sup>
	NOx	1,238x10 <sup>-2</sup>
	SO <sub>2</sub>	6,05x10 <sup>-3</sup>
	CO <sub>2</sub>	3,09x10 <sup>-3</sup>
Total (Kg/Kg de Fuel)		2,555
Ecological Efficiency (%) (Efficiency of the boiler = 84,91%)		46,27

### 3.3 Discussion of the results of the first stage of analysis of conventional exergy and exergo-economics

The heat exchangers of the fuel storage tank (TAC) and the daily fuel tank (TDC), obtained the lowest exergy performance of the system, 3.14%, and 3.96% respectively, results that correspond to those achieved by Vučković, GD and other authors [8]. They are the consequence of the 2 main sources of irreversibilities that exist in this type of components: the heat conduction in the finite temperature differences and the flow friction infinite pressures [24].

Exergy losses are mainly related to exhaust gases and the transfer of exergy to the environment. Of the total exergy losses, the exhaust gas loss is 90.54% or 159.5 kW. All losses of exergy represent 5.47% or 176.154 kW of the exergy of fuel supplied to the system. In the components of the system, 72.82% of the exergy of the input fuel is destroyed or 2345.74 kW. The values for the exergy destruction ratio indicate that the boiler has the greatest impact on the reduction of the exergy efficiency of the global system, that is, 70.94%. The exergy destruction of the other components reduces the exergy efficiency of the general system by just 1.036%.

The circulation pumps (BF1; BF2; BA1) have the greatest improvement potential (%) using the best available technology (more than 80%), but the absolute values of exergy destruction of them are very low (0.026, 0, 06 and 1.2 respectively). The exergetic destruction in the de-aerator (10.31 kW) is mainly caused by differences in temperature and pressure of the water streams that mix. At the discretion of [8] these thermodynamic inefficiencies can be completely avoided if the feed water and steam enter the same temperature and pressure, considering this component of the system isolated. The components of the system with the highest values of the sum  $Z_k + CD_k$  are the steam generator (GV) and the water deaerator (TD), with 50.73 (\$ / h) and 3.21 (\$ / h) respectively, which is mainly due to the cost of the exergy destruction of each of these components, which constitutes the dominant impact in the exergoeconomic evaluation [8].

The exergy efficiency of the boiler reached a value of 25.12%, similar to that described in other studies [25], [26]. The low exergy efficiency can be attributed to the heat transfer that occurs in the boiler under a sharp temperature difference between the gases and the working substance, in addition to the combustion process, which is the major contributor in the destruction of exergy due to the mixture of substances of different natures and with different concentrations and temperatures [6]. The exergy efficiency of the system was 22.62%.

### 3.4 Discussion of the results of the second stage of ecological efficiency analysis

For the steam generation system of the plant, with the use of Fuel Oil # 6 as fuel and thermal efficiency of 84.91%, an ecological efficiency of 46.27% was obtained, results similar to those achieved by [14] for boilers that use fuel oil for the production of steam, which shows the negative environmental impact of the use of this type of fuel, and reaffirms the need to assess the possibility of using other fuels that have a greater ecological efficiency demonstrated according to different authors [10], [14], [23], considering it a feasible option for the case of the tuna industry, those proposed by [14] in their study

#### 4. Conclusion

The greater destruction of exergy in the system is caused by the steam boiler, destroying more than 98% of the exergy of the whole system, for an exergy efficiency of 25.12%, which was evidenced in the conventional exergy analysis, identifying it as the main component of the system to be the subject of an improvement plan. These results could be improved by increasing the steam generation parameters (pressure and temperature). Through the exergo-economic evaluation it was determined that the unit thermoeconomic cost of the steam generated by the steam generation system of the tuna canning plant under study was \$ 28.07 / Gj, a value close to those found for [8; 16] of 22.82 euros / Gj (27.06 \$ / Gj).

The study carried out showed that the ecological efficiency of the steam generator of the canned tuna industrial plant under study, with the use of Fuel Oil # 6 as fuel and a thermal efficiency of 84.91%, It was 46.27%, which shows a negative environmental impact due to the level of contamination generated by the system. These results, interpreted in light of those achieved by [14] in their studies, show the need to assess the possibility of using other fuel alternatives whose ecological efficiency has been demonstrated for the tuna industry.

#### Acknowledgments

SENESCYT had was thanked for having financed the doctorate project and to have allowed carrying out the investigations that today we publish the results obtained.





**References**

1. Nasiri, F., Aghbashlo, M., & Rafiee, S. (2017). Exergy analysis of an industrial-scale ultrafiltrated (UF) cheese production plant: a detailed survey. *Heat and Mass Transfer*, 53(2), 407-424.
2. Atabani, A. E., Mofijur, M., Masjuki, H. H., Badruddin, I. A., Chong, W. T., Cheng, S. F., & Gouk, S. W. (2014). A study of production and characterization of Manketti (*Ricinodendron rautonemii*) methyl ester and its blends as a potential biodiesel feedstock. *Biofuel Research Journal*, 1(4), 139-146.
3. Avadí, A., Bolaños, C., Sandoval, I., & Ycaza, C. (2015). Life cycle assessment of Ecuadorian processed tuna. *The International Journal of Life Cycle Assessment*, 20(10), 1415-1428.
4. Noa Hechavarría, J. J., & Brito Sauwanell, Á. L. (2010). Cálculo termoeconómico de los índices exergéticos del generador de vapor gb-3 de la refinería de petróleo “hermanos díaz”. *Tecnología Química*, 30(2).
5. Mazuera, H., Rojas, B., & Castang, C. (2014). Uso de los análisis de exergía y transferencia de calor para identificar ahorros potenciales de energía en calderas piro-tubulares. *El Hombre y la Máquina*, (45), 7-17.
6. Nuñez Bosch, O. M. (2016). Análisis exergético de una central eléctrica de cogeneración. *Centro Azúcar*, 43(3), 10-20.
7. BoroumandJazi, G., Rismanchi, B., & Saidur, R. (2013). A review on exergy analysis of industrial sector. *Renewable and Sustainable Energy Reviews*, 27, 198-203.
8. Vučković, G. D., Stojiljković, M. M., Vukić, M. V., Stefanović, G. M., & Dedeić, E. M. (2014). Advanced exergy analysis and exergoeconomic performance evaluation of thermal processes in an existing industrial plant. *Energy conversion and management*, 85, 655-662.
9. Jiménez Borges, R., Madrigal Monzón, J. A., Lapido Rodríguez, M. J., & Vidal Moya, D. A. (2016). Método para la evaluación de la eficiencia e impacto ambiental de un generador de vapor. *Ingeniería Energética*, 37(2), 135-143.
10. Cardu, M., & Baica, M. (1999). Regarding a global methodology to estimate the energy–ecologic efficiency of thermopower plants. *Energy Conversion and management*, 40(1), 71-87.
11. Braga, L. B., Silveira, J. L., Da Silva, M. E., Tuna, C. E., Machin, E. B., & Pedroso, D. T. (2013). Hydrogen production by biogas steam reforming: A technical, economic and ecological analysis. *Renewable and Sustainable Energy Reviews*, 28, 166-173.
12. Silveira, J. L., de Queiroz Lamas, W., Tuna, C. E., de Castro Villela, I. A., & Miro, L. S. (2012). Ecological efficiency and thermoeconomic analysis of a cogeneration system at a hospital. *Renewable and Sustainable Energy Reviews*, 16(5), 2894-2906.
13. Bejan, A. (2013). Entropy generation minimization, exergy analysis, and the constructal law. *Arabian Journal for Science and Engineering*, 38(2), 329-340.
14. Coronado, C. R., Carvalho Jr, J. A., Quispe, C. A., & Sotomonte, C. R. (2014). Ecological efficiency in glycerol combustion. *Applied Thermal Engineering*, 63(1), 97-104.
15. Villa, A. A. O., Campos, R. J. A., Dutra, J. C. C., Recarte, J., & Guerrero, H. (2014). Numerical analysis of energetic, exergetic and ecological efficiency by using natural gas and biogas in cogeneration system. *International Journal of Mechanical Engineering and Automation*, 1(1), 31-40.
16. Vučković, G. D., Stojiljković, M. M., & Vukić, M. V. (2015). First and second level of exergy destruction splitting in advanced exergy analysis for an existing boiler. *Energy Conversion and Management*, 104, 8-16.
17. Avadí, A., & Fréon, P. (2013). Life cycle assessment of fisheries: a review for fisheries scientists and managers. *Fisheries Research*, 143, 21-38.
18. Gómez, M. T., Iglesias, A. M., López, R. T., & Bugallo, P. B. (2016). Towards sustainable systems configurations: application to an existing fish and seafood canning industry. *Journal of cleaner production*, 129, 374-383.
19. Arteaga-Linzan, Á. R., Fernández-Parra, M. I., & Brito-Sauvanell, Á. L. (2017). Energy-Economic Evaluation in the Production of Canned Tuna in Ecuadorian Industry. *Revista Ciencias Técnicas Agropecuarias*, 26(3).
20. Bejan, A. (1996). Entropy generation minimization: The new thermodynamics of finite-size devices and finite-time processes. *Journal of Applied Physics*, 79(3), 1191-1218.
21. Atmaca, A., & Yumrutaş, R. (2014). Thermodynamic and exergoeconomic analysis of a cement plant: Part II—Application. *Energy Conversion and Management*, 79, 799-808.
22. Tsatsaronis, G., & Winhold, M. (1985). Exergoeconomic analysis and evaluation of energy-conversion plants—I. A new general methodology. *Energy*, 10(1), 69-80.
23. Madeira, J. G. F., Boloy, R. A. M., Delgado, A. R. S., Lima, F. R., Coutinho, E. R., & de Castro Pereira Filho, R. (2017). Ecological analysis of hydrogen production via biogas steam reforming from cassava flour processing wastewater. *Journal of cleaner production*, 162, 709-716.

24. Gao, B., Bi, Q., Nie, Z., & Wu, J. (2015). Experimental study of effects of baffle helix angle on shell-side performance of shell-and-tube heat exchangers with discontinuous helical baffles. *Experimental thermal and fluid Science*, 68, 48-57.
25. Anozie, A. N., & Ayoola, P. O. (2012). The influence of throughput on thermodynamic efficiencies of a Thermal Power Plant. *International Journal of Energy Engineering*, 2(5), 266-272.
26. Saidur, R., Ahamed, J. U., & Masjuki, H. H. (2010). Energy, exergy and economic analysis of industrial boilers. *Energy policy*, 38(5), 2188-2197.
27. Delgado, G. R. E., Meza, A. K. T., & García, A. E. G. (2018). Resilient Factors in Students with Disabilities. *International Research Journal of Management, IT and Social Sciences (IRJMIS)*, 5(2), 23-31.
28. Mora, M. M., Espinosa, M. R., & Delgado, M. R. (2018). Approach of Processes for the Distribution of Economic Resources in Public University of Ecuador. *International Research Journal of Management, IT and Social Sciences (IRJMIS)*, 5(1), 25-35.
29. Cedeño, M. L. G., Meza, A. K. T., & Mejía, R. G. C. (2018). Resilience and Support Networks for University Students with Disabilities. *International Research Journal of Management, IT and Social Sciences (IRJMIS)*, 5(2), 164-174.

**Biography of Authors**

	<p>Ángel Rafael, Mechanical Engineer, full time professor of the mechanical engineering department, in the Faculty of Physical and Chemical Mathematical Sciences of the Universidad Técnica de Manabí, he has a master's degree in sciences "energy" from the Polytechnic school of Chimborazo, and is currently doing a Ph.D. in engineering technical sciences at the Universidad de Oriente in Santiago de Cuba.</p>
	<p>Ph.D. Angel Luis, Was graduated as an Industrial thermoenergetic engineer in the Polytechnical Zhdanov University (Ukrania) 1983. He teaches in the Mechanical Engineering Faculty, Universidad of Oriente. He presented his Ph.D. Thesis in 1997 and become Professor Titular in the Study Centre of Efficiency Energetic 2000. Skill and expertise have was focused on energy studies and technologies for the thermal conversion of biomasses. He was working for several years to researching in biomass thermoconversion for different sugar industries in Cuba. He has coordinated projects and publishes several papers in peer review journal.</p>
	<p>María Isabel, Mechanical Engineer specialized in Thermoenergetic graduated in the Energetic Faculty of the University of Oriente of Cuba in 1982. Since 1982 has been working as a professor in the same institution first at the Energetic faculty that later was integrated with the Mechanical Faculty. She obtained his Ph.D. in 2003 at the State University of Campinas, State of San Pablo Brazil, and in December of the same year became Titular Professor of the Study Center of Energy Efficiency. She's skill and expertise is the focus on energy and thermoeconomic studies of energy systems and the energy efficiency of the refrigeration systems. She has been working for several years in the use of solar energy, and the environmental problems of the refrigeration systems</p>