



The Effect of Tax Amnesty and Taxpayer Awareness to Taxpayer Compliance with Financial Condition as Intervening Variable



Oyong Lisa ^a
Bambang Hermanto ^b

Article history:

Received: 10 September 2017

Revised: 25 February 2018

Approved: 15 March 2018

Published: 23 March 2018

Keywords:

Tax Amnesty;

Taxpayer Awareness;

Tax Compliance;

Abstract

This study aimed to analyze the influence Tax Amnesties and awareness of taxpayer on the financial condition and taxpayer compliance, analyze the influence of financial condition on tax compliance and to analyze the influence of Tax Amnesties and awareness of taxpayers on tax compliance with financial conditions as moderating. Analysis using techniques *Structural Equation Modeling (SEM)*. The result showed that Tax Amnesties and awareness of taxpayer have a significant effect on financial condition and taxpayer compliance. Then, the financial condition has a significant effect on tax compliance. The result also showed that Financial Condition is mediating the effect of Tax amnesties and tax payer's awareness of tax compliance. The financial condition strengthens the relationship between the Tax amnesties and awareness of taxpayers with tax compliance in paying taxes. If the taxpayer has the willingness to pay tax, compliance in paying taxes will be high when supported with tax payer's financial condition.

2395-7492© Copyright 2018. The Author.

This is an open-access article under the CC BY-SA license
(<https://creativecommons.org/licenses/by-sa/4.0/>)

All rights reserved.

Author correspondence:

Oyong Lisa,

Gajayana University of Malang, Indonesia

Email address: oyong.lisa_ol@yahoo.co.id

1. Introduction

Tax is a tool for government in revenue acceptance, either directly or indirectly from the community and using to funding routine expenditures as well as the national and economic development of the community. Taxes are dynamics as the social and economic development of country and society. In order to achieve target of tax revenue, Government shall conduct organizational changes and business process renewal through Institutional Transformation of Directorate General of Taxation based on PMK No.260.2/PMK/2015 on Organization and Working Procedure of Vertical Institution of Directorate General of Taxation and implement Tax Amnesty regulated according to Regulation of Minister of Finance No.91/PMK.03/2015 on the Reduction or Elimination of Administrative Sanctions for Late Delivery of Notices. Through these steps, it is expected that the Directorate General of Taxation can realize the direction of fiscal policy 2015 based on the Act of the State Budget by achieving the target of tax revenue imposed by the Act. According to Baer (2008) Tax Amnesty is a limited

^a Gajayana University of Malang, Indonesia

^b Politehnik LP3I Jakarta, Indonesia

opportunity given by the government to certain groups of taxpayers to pay the prescribed amount, in exchange for exemption of tax obligations (including interest and penalties) relating to previous tax period. Under the Tax Amnesty Policy, taxpayers still paying all taxes owed. Nevertheless, calculation of tax payable may be based on provisions of tax laws and regulations applicable at the time of the Tax Amnesty program implemented. Provision of exemption of administrative sanctions and exemption from criminal sanctions is most commonly provided in the Tax Amnesty program. Research of [Ngadiman and Huslin \(2015\)](#) proved that Tax amnesty influence to taxpayer compliance.

Compliance of taxpayers in paying their tax obligations is important in tax collection. The main cause of lack of awareness to paying taxes is lack of tax benefits that can be enjoyed by taxpayers. Society itself, in fact, do not like to pay taxes. Its caused by people that never know the real tax benefits ([Widayati and Nurlis, 2010](#)). Taxpayer compliance will increase as increasing of tax payer's awareness ([Nugroho, 2006](#)). [Putri and Jati \(2012: 672\)](#) stated that taxpayer's awareness factor has a positive effect on taxpayer compliance in paying taxes.

While taxpayers pay the tax, must also consider their financial condition. If their income received exceeds taxable income (PPP), the taxpayer is required to pay taxes and required to report their income tax. Taxpayers must also be exposed the risks to be considered when a taxpayer will perform his obligations in paying taxes. Risks that taxpayers often consider include health risks, financial risks, social risks, occupational risks and safety risks ([Aryobimo, 2012](#)). Awareness to improve tax compliance is necessary to cause tax needed for development and improve community's welfare and it means to realize a sense of nationalism. [Aryobimo \(2012\)](#) study proved that taxpayer perceptions about quality of tax service, financial condition, and taxpayer risk preference proved to have a positive effect on taxpayer compliance. In addition, the variable of financial condition and taxpayer risk preference also as a moderating variable. The financial condition of taxpayer positively affects the relationship between taxpayer's perception to the quality of tax service and taxpayer compliance.

The purpose of this study is to analyze the effect of Tax amnesty and taxpayer awareness to financial condition, analyze influence of Tax amnesty and awareness of taxpayer to taxpayer compliance, analyze influence of financial condition to taxpayer compliance and analyze influence of tax amnesty and taxpayer awareness to compulsory compliance Tax with financial condition as Intervening Variable.

2. Research Methods

2.1 Research variable

1) Tax amnesty (X1)

Tax amnesty is a tax abolition that should be payable, not subject to tax administration sanctions and criminal sanctions in the field of taxation by disclosing property and paying the ransom. The tax amnesty indicator consists of perceptions regarding the reduction or elimination of administrative sanctions for late delivery of notices, correction of notices, and late payments or deposits of taxes.

2) Taxpayer awareness (X2)

Taxpayer awareness is a condition in which taxpayer knows, understands and implements provisions of taxation correctly and voluntarily. Indicators used in the consciousness of taxpayer consist of the knowledge level of tax functions for state financing; The degree of understanding that tax obligations should be implemented in accordance with applicable regulations; Level of understanding of tax functions for state financing; And calculate, pay and report taxes correctly.

3) Financial condition (Y1)

Financial condition is the level of establishment of the company's real financial condition in a certain period. The financial condition indicator consists of profitability level, cash flow rate and profit before tax.

4) Taxpayer compliance (Y2)

Taxpayer compliance is an attitude that obeys the law and has a decision to fulfill his tax obligation and obey the rules relating taxes. Indicators in this study consist of taxpayer compliance in registering, compliance to reporting back Notification Letter (SPT), compliance with the calculation and payment of tax payable and compliance in payment of arrears.

2.2 Population and Sample

Population in this study are corporate taxpayers or companies registered in KPP Pratama Lumajang District as many as 17,770 taxpayers. Determination of sample using Slovin formula:

$$n = \frac{N}{(1 + Ne^2)}$$

Description:

n = number of samples

N = total population

e = percent looseness of non-attachment due to desirable sampling error.

$$N = \frac{17.770}{(1 + 17.770 \cdot 0,1^2)} = \frac{17.770}{178,7} = 100$$

The number of samples in this study as many as 100 taxpayers. Sampling technique used is a simple random sampling of a probability sampling type. The researcher chooses a sample by giving equal opportunity to all members of the population to be defined as a sample member.

2.3. Data analysis technique

To test hypothesis used SEM analysis tool (Structural Equation Modeling) with AMOS Software. The basis of SEM analysis is factor loading analysis and regression weight analysis.

3. Results and Analysis

3.1 Results of SEM Analysis

1) Normality test

Based on the result of processing obtained CR value of multivariate equal to 1,396 which is between -2,58 to 2,58, then concluded multivariate normality assumption has been fulfilled, thus assumption of normality needed by SEM analysis have been fulfilled.

2) Outlier test

The result of Mahalanobis distance squared shows that there are statistically observed detected as outlier that is observation having Mahalanobis distance bigger than chi-square table (df = 14, $\alpha = 0,001$) that is 36,12 from result analyze known that at 14 indicators that used in this study has a value below 36.12 so that no one contains an outlier.

3) Evaluation of multicollinearity

The output of matrix correlation between service qualities with trust is 0,724. The results of this evaluation indicate that there is no multicollinearity problem.

4) Results of SEM analysis

In accordance with the study of literature and research objectives, then developed the overall structural model as follows:

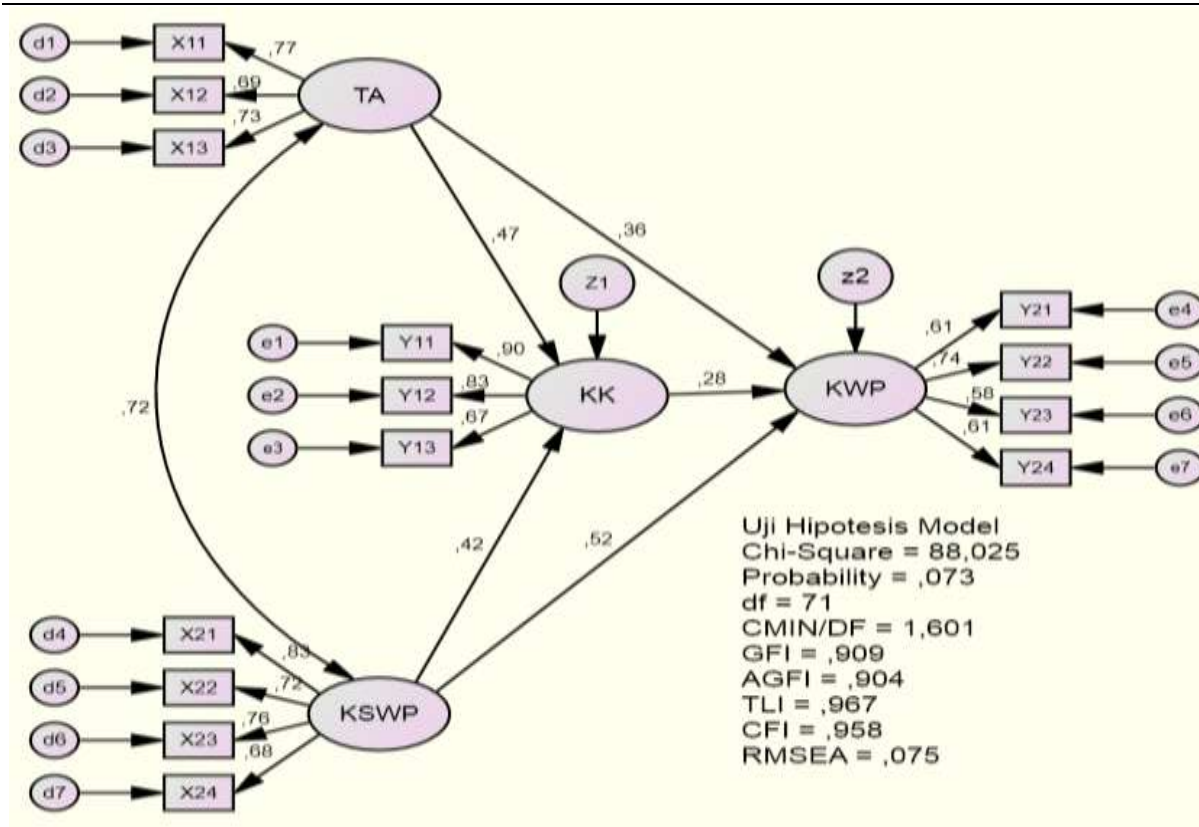

Information:

- TA : Tax amnesty
- KSWP : Taxpayer awareness
- KK : Financial condition
- KWP : Taxpayer compliance

Source: Primary data processed.

Figure 1. Results of SEM Analysis

Table 1
 Test result of goodness of fit modified structural model

Goodness of Fit Index	Cut-of Value	Model Results	Note
Chi-Square (df = 71)	91,67	88,025	Good
Probability Chi-Square	> 0,05	0,073	Good
CMIN/DF	≤ 2,00	1,601	Good
RMSEA	≤ 0,08	0,075	Good
GFI	≥ 0,90	0,909	Good
AGFI	≥ 0,90	0,904	Good
CFI	≥ 0,95	0,958	Good
TLI	≥ 0,95	0,967	Good

Source: Primary data processed.

Based on the evaluation results of the Goodness of Fit Indices criteria, it shows that the overall model evaluation has met, the model is acceptable.

3.2 Hypothesis testing

1) Hypothesis testing one

Hypothesis one states that Tax amnesty and awareness of taxpayers affect the financial condition. Based on the results of analysis on testing the hypothesis one as shown in Table 2.

Table 2
Tax amnesty and awareness of taxpayers affect the financial condition

Variable	Factor Loading		S.E.	C.R.	P
	Standardized	Estimate			
	Regression Weight				
Tax amnesty	0,472	0,576	0,182	3,169	0,002
Tax payer awareness	0,422	0,568	0,190	2,993	0,003

Source: Primary data processed.

Based on the above table, we get the equation model as follows:

$$FC = 0.368 TA + 0.482 TAW$$

Table 2 shows that tax amnesty variable and taxpayer awareness have critical ratio value (CR) greater than 2 and p-value is less than or equal to 0.05. In standardized form, the coefficient of loading factor amnesty tax is 0.368, and the consciousness of the taxpayer is 0.482. These results provide a decision that variable tax amnesty and awareness of taxpayers have a positive and significant impact on financial condition. The hypothesis of research that stated that tax amnesty and awareness of taxpayers affect the financial condition is statistically proven (acceptable).

2) Hypothesis testing two

Hypothesis two stated that Tax amnesty and awareness of taxpayers affect taxpayer compliance. Based on the results of the analysis on testing the hypotheses two as shown in Table 3.

Table 3
Tax amnesty and awareness of taxpayers affect taxpayer compliance

Variable	Factor Loading		S.E.	C.R.	P
	Standardized	Estimate			
	Regression Weight				
Tax amnesty	0,357	0,315	0,125	2,511	0,012
Awareness of taxpayers	0,516	0,502	0,132	3,798	0,000

Source: Primary data processed.

Based on the above table, we get the equation model as follows:

$$TC = 0.586 TA + 0.322 TAW$$

Table 3 shows that tax amnesty and taxpayer awareness variables have CR value greater than 2 and p-value smaller than or equal to 0.05. In the form of standardized coefficient factor loading tax, amnesty is worth 0.357, and the consciousness of taxpayer is 0.516. These results provide the decision that variable tax amnesty has a positive and significant effect on taxpayer compliance, and taxpayer awareness variable has a positive and significant impact on taxpayer compliance. Hypothesis of research that stated that tax amnesty and awareness of taxpayers affect taxpayer compliance is statistically proven (acceptable).

3) Testing of the third hypothesis

The third hypothesis stated that financial condition affects taxpayer compliance. Based on results of the analysis on testing the third hypothesis as shown in Table 4.

Table 4
Financial condition affect taxpayer compliance

Variable	Factor Loading		S.E.	C.R.	P
	Standardized	Estimate			
	Regression Weight				
Financial condition	0,280	0,202	0,100	2,020	0,043

Source: Primary data processed.

Based on the above table, we get the equation model as follows:

$$TC = 0.280 FC$$

Table 4 shows that the financial condition variable has a CR value greater than 2 and the p-value is less than or equal to 0.05, the standardized value of the loading factor coefficient of 0.280. These results provide the decision that the variable financial condition has a positive and significant effect on taxpayer compliance, thus the third hypothesis is statistically proven (acceptable).

4) Hypothesis testing fourth

Hypothesis four stated that Tax amnesty and taxpayer awareness affect taxpayer compliance with the variable financial condition as Intervening. Based on results of the analysis of the four hypothesis testing as shown in Table 5.

Table 5
The result of influence of tax amnesty and awareness of taxpayer to compliance
a taxpayer with financial condition as intervening variable

Variable	Direct Effect	Influence Indirect	Influence Total
Tax amnesty to taxpayer compliance with financial condition as Intervening variable	0,357	$0,472 \times 0,280 = 0,132$	0,489
Taxpayer awareness of taxpayer compliance with financial condition as Intervening variable	0,516	$0,422 \times 0,280 = 0,118$	0,634

Source: Primary data processed.

Based on the above table, we get the equation model as follows:

$$KWP = 0,357 TA + (0,472 TA \times 0,280 KK)$$

$$KWP = 0.516 KSWP + (0.422 KSWP \times 0.280 KK)$$

Based on Table 5, the analysis shows that financial condition is an intervening variable that can mediate tax amnesty variable because the total influence value is greater than the direct effect. Financial condition is an intervening variable that can mediate the taxpayer awareness variable to taxpayer compliance since the total value of influence is greater than the direct effect. This means tax amnesty and taxpayer awareness have an effect on taxpayer compliance with the variable of financial condition as Intervening is statistically proven (acceptable).

3.3. Discussion

Influence of tax amnesty and taxpayer awareness to financial condition

Tax amnesty affects the financial condition, indicating that tax amnesty is one of the programs implemented by the Government to grant pardons to taxpayers who committed past abuses. This is done by the Directorate General of Taxes with a team that has been established by involving the ministries of law and legislation, the police, and the competent parties. The purpose of this program is to give the taxpayers or taxpayer a chance to pay taxes according to tax object, not to manipulate the tax, not tax arrears, and have the right and right to pay the tax, which affects the company's financial condition more and better. Any taxpayer who has not fulfilled his tax obligations is allowed to participate in the tax amnesty program. That is, tax amnesty program is addressed to taxpayers who have been in the tax administration system and taxpayers who have not entered the tax administration system.

Taxpayer awareness affects the financial condition, which means that the higher level of awareness of taxpayer in terms of knowledge level of tax function for state financing; The degree of understanding that tax obligations should be implemented in accordance with applicable regulations; Level of understanding of tax functions for state financing; And calculating, paying, reporting taxes correctly indicates that the financial condition is in good condition. As the concept of [Suandy \(2011: 128\)](#) which stated that consciousness of taxpayers means taxpayers themselves want to perform the obligations of taxation such as registering, calculating, paying and reporting the amount of taxes payable. This is caused the financial condition of the taxpayer is in good condition.

Effect of tax amnesty and taxpayer awareness to taxpayer compliance

Tax amnesty affects taxpayer compliance, which means that tax amnesty is believed to comply with taxpayers to pay their taxes. In addition, tax amnesty is also believed to be a system of detection tools to find out which taxpayers are not complying with taxes. Improving taxpayer tax compliance is the first goal of reform of medium-term tax administration. There are three strategies that will be implemented to achieve this goal, namely, first, by creating programs and activities that are expected to awaken and improve voluntary compliance, especially taxpayers who have not been obedient. Secondly, increasing the services of relatively compliant taxpayers so that the level of compliance can be maintained or enhanced. Third, to improve tax compliance is to combat non-compliance with programs and activities that are expected to counteract tax compliance. The government's goal in enacting tax amnesty policy is to increase tax revenue in the short term. The results of research in accordance with research [Ngadiman and Huslin \(2015\)](#) which stated that tax amnesty affects taxpayer compliance.

Taxpayer awareness affects taxpayer compliance, it indicates that higher taxpayer awareness can impact on taxpayer compliance. Awareness of taxpayers depends on each individual, either from the observation of others and personal experience, so that if the awareness of taxpayers continues to increase, then taxpayer compliance will also increase. Taxpayers who have high tax awareness will understand the functions and benefits of taxes, both understand for the community and itself. Results of this research in line with [Tryana \(2013\)](#) study which stated that tax awareness has a significant effect on taxpayer compliance of individuals because taxation awareness will only be a matter of consideration for them to deposit tax amount charged to the taxpayer. As the concept of [Harahap \(2004: 43\)](#) stated that consciousness of taxpayer is the attitude to understand corporate taxpayers or individuals to understand the meaning, function, and purpose of tax payments.

Influence of financial condition against taxpayer compliance

The financial condition has a positive effect on taxpayer compliance level, it shows that better financial condition of the company is seen from level of profitability, level of cash flow and profit before tax, the taxpayer compliance rate tends to increase. Therefore, if a taxpayer is in a position of low financial condition then has more tendency to disobey in paying its tax liability than if the taxpayer is in good financial condition. This is in accordance with [Bloomquist \(2008\)](#) research that financial pressure as a source of pressure for taxpayers and Bloomquist also argued that taxpayers of individuals with limited incomes may avoid tax payments if taxpayer's financial condition is bad because his family expenditure is more of its revenue.

Effect of tax amnesty and taxpayer awareness to taxpayer compliance with financial condition as intervening variable

Tax amnesty is an alternative to improve taxpayer compliance and in addition to raising awareness of taxpayers and prospective or former taxpayers through tax amnesty. Proponents of tax amnesty generally argue that voluntary compliance will increase after-tax amnesty program implemented. This is based on the expectation that after-tax amnesty program done taxpayer which previously not yet become part of tax administration system will enter become part of tax administration system. Becoming part of tax administration system, the taxpayer will not be able to avoid obligations of taxation. In addition, in making tax payments, taxpayers must also consider their financial condition, the better financial condition of taxpayer tends to increase taxpayer compliance. As [Torgler \(2007\)](#) concept stated that a person with financial difficulties will feel depressed when they have to pay their obligations including taxes. Thus tax amnesty represented by the perception of reduction or elimination of administrative sanctions for delay of delivery of notice. Awareness of taxpayer is reflected from knowledge level of tax function for the state financing, will foster taxpayer compliance, but without financial condition, taxpayer compliance will be negative.

4. Conclusion

Based on results of the analysis it can be concluded as follows:

- 1) Tax amnesty and awareness of taxpayers have a significant effect on financial condition, which means that the presence of tax amnesty and the higher level of awareness of taxpayers can improve the financial condition of taxpayers.
- 2) Tax amnesty and awareness of taxpayers have a significant effect on taxpayer compliance, which means that the presence of tax amnesty and the higher level of awareness of taxpayers can improve taxpayer compliance.
- 3) The financial condition of taxpayer compliance, which means that better financial condition of company seen from the level of profitability, cash flow, and profit before tax then level of taxpayer compliance tends to increase.
- 4) Financial condition able to mediate the influence of tax amnesty and awareness of taxpayers has a significant effect on taxpayer compliance.



Acknowledgments

Our deep and sincere gratitude is given to God for giving us the ability and opportunity to complete this paper. We also want to thank my friends for their support, patience, their contribution, and their valuable feedback, therefore, this article can be completed.

References

- Agusti, A. F., & Vinola, H. (2009). Perpajakan: Pengaruh Tingkat Kepatuhan Wajib Pajak Badan Terhadap Peningkatan Penerimaan Pajak Yang Dimoderasi Oleh Pemeriksaan Pajak Pada Kpp Pratama.
- Aryobimo, P. T., & Cahyonowati, N. (2012). *Pengaruh Persepsi Wajib Pajak tentang Kualitas Pelayanan Fiskus terhadap Kepatuhan Wajib Pajak dengan Kondisi Keuangan Wajib Pajak dan Preferensi Risiko sebagai Variabel Moderating (Studi Empiris terhadap Wajib Pajak Orang Pribadi di Kota Semarang)* (Doctoral dissertation, Fakultas Ekonomika dan Bisnis).
- Bloomquist, K. M. (2003). US income inequality and tax evasion: A synthesis. *Tax Notes International*, 31(4), 347-368.
- Fidel. (2010). *Cara Mudah dan Praktis Memahami Masalah–Masalah Perpajakan*. Jakarta: Murai Kencana.
- Hadi, A., Handajani, L., & Putra, I. N. N. A. (2018). Financial Disclosure based on Web-ICT Determinants: Its Implications for Local Government Financial Performance in Indonesia. *International Research Journal of Management, IT and Social Sciences (IRJMIS)*, 5(1), 72-85.
- Harahap, S. S. (2004). *Analisis Kritis Atas Laporan Keuangan*. Edisi Pertama. Cetakan Keempat. Jakarta: PT. Raja Grafindo Persada.
- Kustina, K. T., Dewi, I. G. A. A. O., Prena, G. D., & Utari, I. G. A. D. (2018). MSMEs Credit Distribution and Non-Performing Loan towards Banking Companies Profit in Indonesia. *International Journal of Social Sciences and Humanities (IJSSH)*, 2(1), 10-23.
- Larasati, L. D. (2013). *Pengaruh Persepsi Tentang Sanksi Perpajakan, Kesadaran, Dan Karakteristik Personal Wajib Pajak Pada Kepatuhan Pelaporan Wajib Pajak Orang Pribadi (Studi Kasus Pada Kantor Pelayanan Pajak Pratama Boyolali)*(Doctoral dissertation, Universitas Muhammadiyah Surakarta).
- Le Borgne, E., & Baer, K. (2008). *Tax amnesties: Theory, trends, and some alternatives*. International Monetary Fund.
- Nasucha, C. (2004). *Reformasi administrasi publik: teori dan praktik*. Gramedia Widiasarana Indonesia (Grasindo).
- Ngadiman, N., & Huslin, D. (2015). Pengaruh Sunset Policy, Tax Amnesty, Dan Sanksi Pajak Terhadap Kepatuhan Wajib Pajak (Studi Empiris di Kantor Pelayanan Pajak Pratama Jakarta Kembangan). *Jurnal Akuntansi*, 19(2), 225-241.
- Nugroho, A. J. (2006). Pengaruh Sikap Wajib Pajak pada Pelaksanaan Sanksi Denda, Pelayanan Fiskus, dan Kesadaran Perpajakan Terhadap Kepatuhan Wajib Pajak Studi Empiris Terhadap Wajib Pajak Orang Pribadi di Kota Semarang. Unisversitas Diponegoro: Tesis Magister Akuntansi.
- Pemayun, A. G. P., & Maheswari, A. I. A. (2017). Economic Impacts of Craftsman Statue on Community Based Tourism Development. *International Journal of Social Sciences and Humanities (IJSSH)*, 1(3), 59-73.
- Putri, A dan Jati, I. K. (2012). Faktor-Faktor yang Mempengaruhi Kepatuhan Wajib Pajak dalam Membayar Pajak Kendaraan Bermotor di Denpasar. *E-Jurnal Akuntansi Universitas Udayana*. Vol. 2 No.3: 661-677
- Suandy, E. (2011). Perencanaan pajak. *Jakarta: Salemba Empat*.
- Tiraada, T. A. (2013). Kesadaran perpajakan, sanksi pajak, sikap fiskus terhadap kepatuhan wpop di kabupaten minahasa selatan. *Jurnal EMBA: Jurnal Riset Ekonomi, Manajemen, Bisnis dan Akuntansi*, 1(3).
- Torgler, B. (2007). *Tax compliance and tax morale: A theoretical and empirical analysis*. Edward Elgar Publishing.

Biography of Authors

	<p>Education Background Bachelor : Accounting, STIE “WIGA GAMA” Lumajang, Indonesia Master : Financial, UNMUH Malang, Indonesia Doctor : University of Merdeka Malang, Indonesia</p> <p>Publication :</p> <ol style="list-style-type: none"> a) Analisis Faktor-Faktor yang Mempengaruhi permintaan Audit pada KPRI Kabupaten Lumajang (2011) b) Asimetri Informasi dan Manajemen Laba Suatu Tinjauan Dalam Hubungan Keagenan(2012) c) Analisis Faktor-Faktor yang Mempengaruhi permintaan Jasa Audit Eksternal pada Koperasi Di Jawa Timur (2013) d) ID90-Firm Characteristic, External Auditing Service and Financial Performance: An Empirical Study on Cooperative Enterprises in East Java-Indonesia,(2013) e) Analysis Effect of Member, Scale Cooperative and Total Liabilities request for External Audit and Implications on Financial Performance of Cooperation in East Java Indonesia(2014) f) Analisis pengaruh Anggota, Skala Koperasi, Jumlah Kewajiban dan Struktur Modal Terhadap Permintaan Audit Eksternal Koperasi Di Jawa Timur (2014) g) Factors that Trigger The Cooperative Use of the Audit Services In East Java h) Karakteristik Koperasi untuk membedakan Pengaruhnya Terhadap Permintaan Jasa Audit Eksternal (2014) i) Firm Characteristic, Demand for External Auditing Service and Financial Performance: An Empirical Study on Cooperative Enterprises in East Java-Indonesia (2014) j) Analisis Faktor-Faktor yang mempengaruhi Audit Delay (Study Empiris pada perusahaan Manufactur yang terdaftar di Bursa Efek Indonesia (2015) k) Determinants Distribution of financing And Implications To Profitability (Empirical Study on Cooperative Syariah BMT in Indonesia) (2015) l) Timelines submission financial statements and factors-factors Affecting to cooperative syariah in indonesia incorporated in inkopsyah (2015) m) Karakteristik Koperasi Untuk membedakan pengaruhnya terhadap permintaan Jasa Audit Eksternal (2015) n) Implementation Of Management Zakat as a Lokal Revenue (2015) o) Determinants Audit Delay dan Time Lines p) Diterminan penyaluran pembiayaan pada koperasi syariah baitul maal wattamwil di Indonesia q) Determinants Financing Received And Implications Iclamic City Of Performance Index
	<p>Education Background Bachelor : Accounting Master : Magister Management</p>